

B600 & B5T XT UPGRADE

MORE THAN 50% TORQUE INCREASE OVER 1.25" PISTON

USE MIL-H-5606 HYDRAULIC FLUID

SAFETY WIRE ALL DRILLED BOLTS

* MAY ALSO BE USED WITH BPA1.505T ON 5 INCH WHEELS

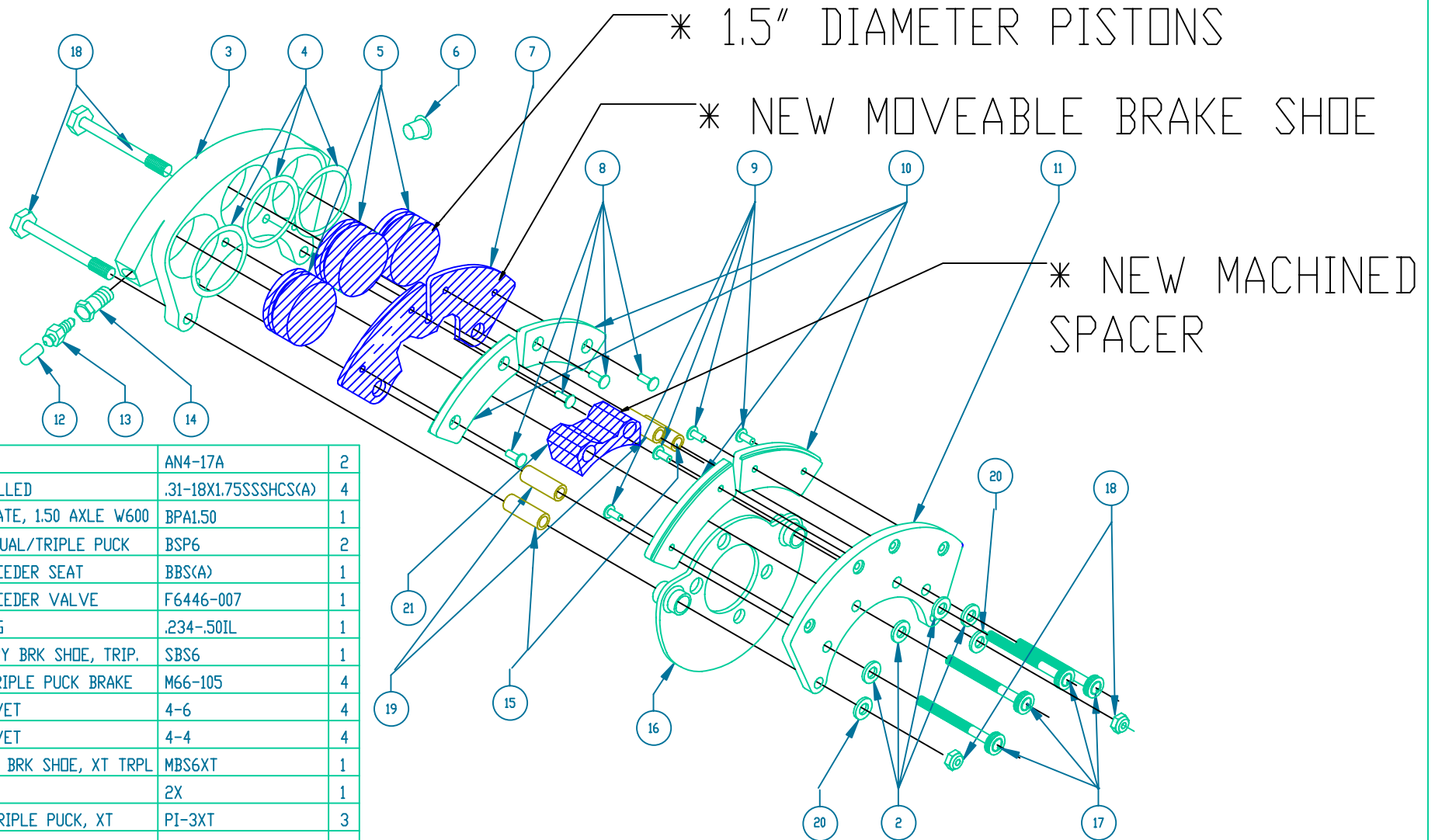

18	BOLT	AN4-17A	2
17	SHCS, DRILLED	.31-18X1.75SSSHCS(A)	4
16	BRAKE PLATE, 1.50 AXLE W600	BPA1.50	1
15	SPACER, DUAL/TRIPLE PUCK	BSP6	2
14	BRAKE BLEEDER SEAT	BBS(A)	1
13	BRAKE BLEEDER VALVE	F6446-007	1
12	DUST PLUG	.234-.50IL	1
11	STATIONARY BRK SHOE, TRIP.	SBS6	1
10	LINING, TRIPLE PUCK BRAKE	M66-105	4
9	BRASS RIVET	4-6	4
8	BRASS RIVET	4-4	4
7	M MOVEABLE BRK SHOE, XT TRPL	MBS6XT	1
6	CAPLUG	2X	1
5	PISTON, TRIPLE PUCK, XT	PI-3XT	3
4	O-RING BUNA N	2-218	3
3	PUCK HOUSING, XT TRIPLE PUCK	PH-6XT	1
2	WASHER	AN960-416L	4
1	LOCK NUT	.25-28NYLDC	2

21	SPACER, W600XT	BSP600XT	1
20	WASHER	AN960-516L	2
19	SPACER, W600	BSP600	2

NO.	PART NAME	INVENTORY NO.	REQ
-----	-----------	---------------	-----

XTUPGRADE MATCO mfg
2361 S 1560 West
WOODS CROSS, UT 84087 (801) 335-0582

TRIPLE PUCK BRAKE ASSEMBLY
USING PH-6XT CALIPER (1.50" PISTONS)

DRAWN BY: G. HAPP

CHECKED BY:

SCALE: NONE

DATE: JUNE 26, 2001

1 OF 1